

INSTRUCTION MANUAL

APW-140 Auto Parts Washer - Floor Model (240V) 140 Litre Tank



A374

A374 140 LITRE **29/8/08**
PARTS WASHER
40 – GALLON

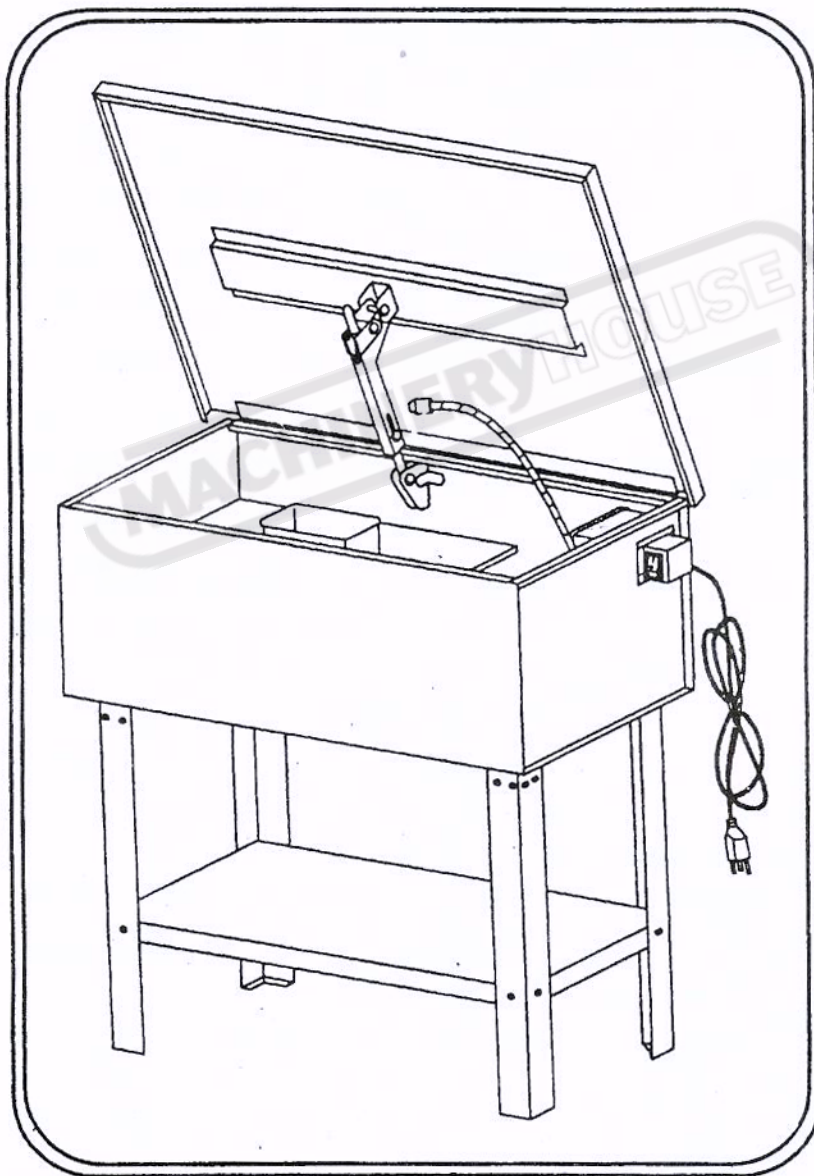

HAFCO PARTS WASHER

MODELS 140 Litre
A374

76 Litre
A368

12 Litre
A370

ADDITIONAL INSTRUCTIONS

CLEANING SOLUTIONS

WARNING

DO NOT USE PETROL

APPROVED CLEANING SOLUTIONS

WATER
WATER/HOUSEHOLD DETERGENTS (PH6-B)
KEROSENE
DIESEL FUEL

**THE PUMP WILL BE DAMAGED IF SOLUTIONS OTHER THAN THE ABOVE
ARE USED AND WARRANTY WILL BE VOID**

DO NOT OVERFILL

MAXIMUM LIQUID LEVEL IS THE TRAY

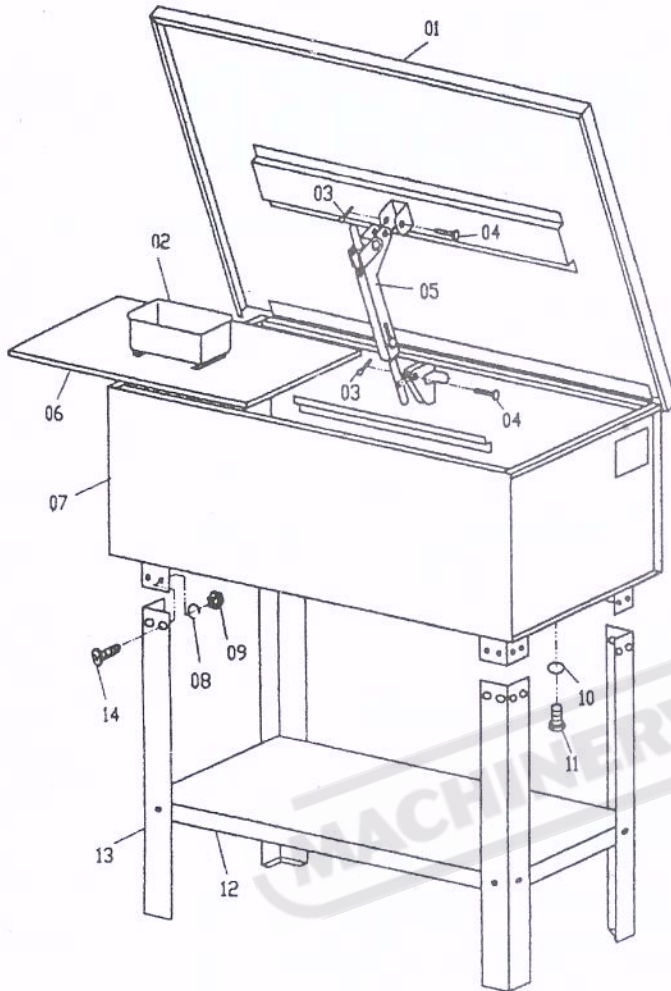

PARTS NO	DESCRIPTION	QTY
01	COVER	1
02	WORK BASKET	1
03	SPRING PAN	4
04	PIN	4
05	SAFETY PLATE	1
06	WORK SHELF	1
07	BODY	1
08	SPRING WASHER	24
09	NUT	24
10	O-RING	1
11	PLUG	1
12	SHELF	1
13	LEG	4
14	PAN SCREW	24
15	NUT	5
16	SPRING WASHER	5
17	SCREW	5
18	STRAIN RELIEF	2
19	CABLE AND PLUG	1
20	PUMP HOUSING	1
21	SCREEN	1
22	SWITCH	1
23	SWITCH BOX	1
24	FLEXIBLE PIPE	1
25	ELBOW SEAT	1
26	PUMP BODY	1
27	PUMP BACK COVER	1
28	FILTER COVER	1
29	PUMP HOUSING COVER	1
30	ELBOW	1
31	PLASTIC WASHER	1
32	SPIGOT	1
33	LOCATION OF KNOB	1
34	FILTER	1
35	SEALRING	1
36	IMPELLER	1
37	SHIN WASHER	2
38	SEALRING	1
39	IMPELLER HOLDER	1

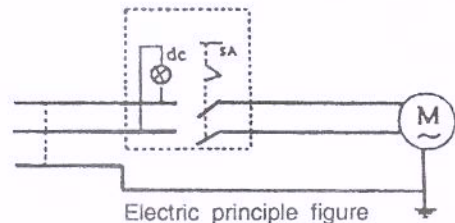
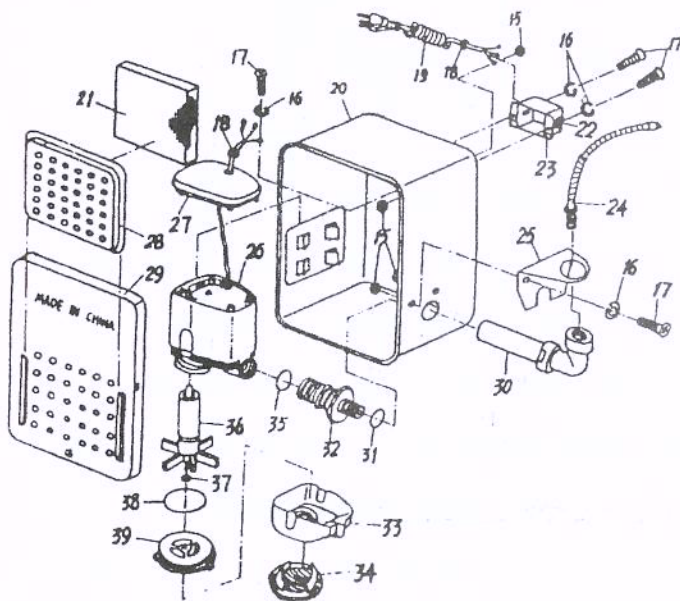

ASSEMBLY INSTRUCTIONS

1. Remove machine from carron and inspect for any visual damage.
2. Remove parts inside the machine.
3. Lay clean and hard cardboard on the floor and lay machine on its lid.
(Make sure you hold cover closed when laying machine on its lid.)
4. Mount four legs on brackets with M6X12 philips head screws and M6 Keps nuts. NOTE: DO NOT TIGHTEN.
5. Place lower shelf between legs with flat surface up and attace to legs with M6X12 philips head screws and M6 keps nuts.
6. With legs press tight against lower shelf, tighten all screws to lower shelf.
7. Tighten all the screws installed in step 4.
8. Stand machine up, be careful to hold lid closed.
9. Put work shelf and basket into the machine.
10. Mount pump assembly into slot on the side of the machine then place filter screen in position.
11. Plug machine into standard 115Volt 60Hz(240Volt 50Hz) grounded outlet and fill with proper amount of fluid.
12. Turn switch on. Fluid should now be flowing from the flexible spigot.

SPECIFICATIONS	Recirculating Parts Washer
Overall Dimensions	115 × 56 × 90CM
Tank Dimensions	113.5 × 54.5 × 32CM
Max Solvent Capacity	40. Gallons
Max Pump Output Through Spigot	20L/min
ELectrical Requirements	115V/60Hz/0.5A(240V/50Hz/0.5A)
Gross Weight	45kg

CLEANING SOLUTIONS

Approved cleaning solutions:

Water/household detergents (PH6 ~ 8)

WARNING

The pump of your Parts Washer may be damaged if you use solvents other than those listed above such as methyl ethyl ketone (MEK), Perchloroethylene or trichloroethylene.

TROUBLE SHOOTING

The only trouble you should ever experience with your Parts Washer is reduced volume flow or on flow of cleaning liquid from the flex hose nozzle. The probable cause is foreign matter in the flex hose.

CORRECTIVE PROCEDURE

1. Check if indicator light on switch box is lit.
2. Using an insulated handle screw driver to lightly touch tip of housing of motor.
A light oscillation magnetic pull indicates power is reaching the motor.
3. Disconnect power plug, remove flex hose from pump flow-out line.
4. Remove front of pump housing by removing 3 screws. Clean any foreign matter lodged around impeller.
5. Reassemble in reverse order.